

SPECTRUM™

# HYBRID PARTIAL INSERT READER

## Intelligent OEM Module

for Magnetic Stripes and/or Smart Cards  
RS-232, USB, and PC/SC Interface

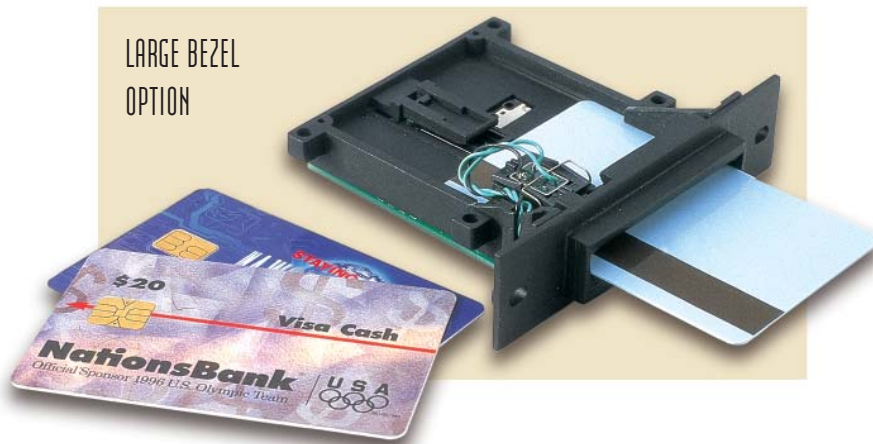

### Reads magnetic stripes and smart cards.

ID TECH's Spectrum Hybrid Partial Insert Reader is designed to read on insertion and decode approximately 2½ inches of magnetically-encoded information on one to three tracks. It reliably reads media encoded to meet ISO 7811 standards. The reader can also be configured to read and write to Integrated Circuit Cards (ICC or "smart" cards), memory or microprocessor cards conforming to ISO 7816 standards. The Reader itself is approved to EMV specification 3.1.1, and is able to communicate with a host PC via the Microsoft PC/SC smart card interface, if desired. A "card seated" switch signals when the card has been inserted into the unit and full connection has been made with the ICC contacts.

### Designed for a wide range of applications.

The reader has "card detect" switches both front and back, so it's easy to tell when the card is fully seated and when it is either partially or fully withdrawn. Electrostatic Discharge (ESD) protection makes the reader well-suited to dry, carpeted environments. Added pressure on the inserted card keeps it from being accidentally pulled out (if tethered, for instance, by a coiled cord). And optional LEDs can illuminate the slot (or the optional translucent bezel) to make it easier to find and use in low levels of light.

### Selects and formats data.

The ID TECH Hybrid Partial Insert Reader is a fully-intelligent unit that can be programmed to read only selected tracks from a magnetic stripe, or to output data with terminating characters and up to nine preamble or postamble characters in order to match a data format expected by the host.

### Works as a drop-in replacement for other units.

There are two different bezels available with the ID TECH Hybrid Partial Insert Reader, depending on the unit being replaced. Both are reinforced with metal, eliminating the need for the mounting bracket required by most other manufacturers. The reader's chassis is molded from a glass and lubricant-filled engineering plastic that supports the magnetic head as well as a PCB with a landing-style smart card connector. The magnetic head is spring-loaded for good contact with warped or bowed cards. The smart card connector has gold-plated contacts that "land" on the ICC's contacts and create a .02 inch "wiping" action to ensure a dependable connection and long life.

**IDTECH®**  
Value through Innovation

# Spectrum™ Intelligent Partial Insert Reader Specifications

## Electrical

RS-232 or PC/SC:	+5 VDC/70mA (power adapter regulated 5 VDC/350mA or equivalent).
USB/RS-232:	Power supplied by the host computer.
Operating Current:	70 mA maximum for three tracks of magnetic data.
Chassis Ground:	Connected to GND and magnetic head case.
EDS Protection:	A grounded metal plate serves as an anti-static guard and can be grounded to the host's chassis ground, or tied into the common circuit ground.

## Environmental

Operating Temperature:	32° F to 131° F (0° C to 55° C).
Storage Temperature:	-40° F to 158° F (-40° C to 70° C).
Humidity:	Maximum 95% non-condensing.



## Reliability

Magnetic Head Life:	1,000,000 passes minimum.*	*All wear reliability numbers are based on operation in a laboratory environment. **Based upon reading on withdrawal.
IC Card Connector:	1,000,000 cycles minimum.*	
Chassis and Bezel:	1,000,000 card cycles minimum.*	
Read Rate:	Less than one error in 100,000 bits on cards conforming to ISO 7811 - 1/6 (not induced by operator error).**	
Warranty:	One year, parts and labor.	

## Mechanical

Magnetic Stripe Formats:	ISO 7811, F2F.
Reading Speed:	5 to 60 inches per second.
Media Thickness:	.025 to .035 inches.
Dimensions:	<u>Small Bezel</u> Length 3.4 inches (86.35 mm). Width: 3.85 inches (97.74 mm). Height: .93 inches (23.54 mm). <u>Large Bezel</u> Length 3.33 inches (84.51 mm). Width: 3.85 inches (97.74 mm). Height: .93 inches (23.54 mm).
Options:	LED Slot Illumination, Translucent Bezel.
Footprint:	

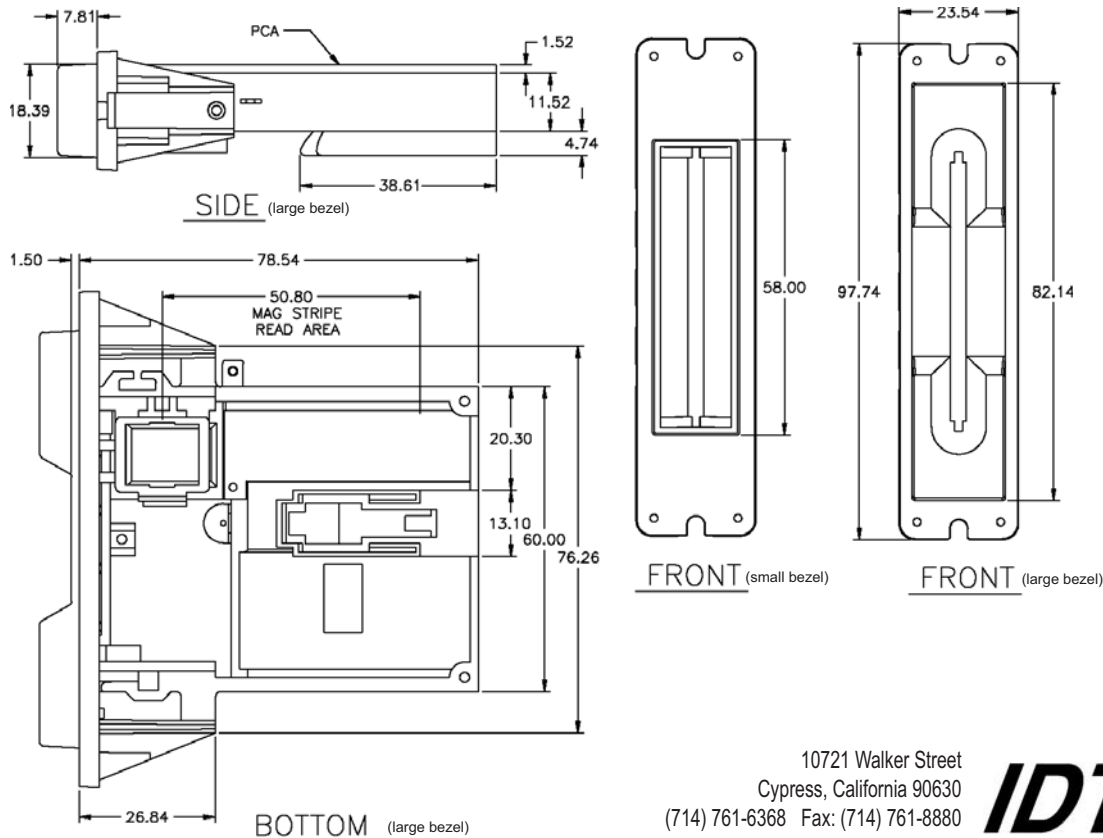

10721 Walker Street  
Cypress, California 90630  
(714) 761-6368 Fax: (714) 761-8880  
Visit us at [www.id-tech.net](http://www.id-tech.net)  
ISO 9001-2000 Certified

**IDTECH**<sup>®</sup>  
Value through Innovation